

Tandon

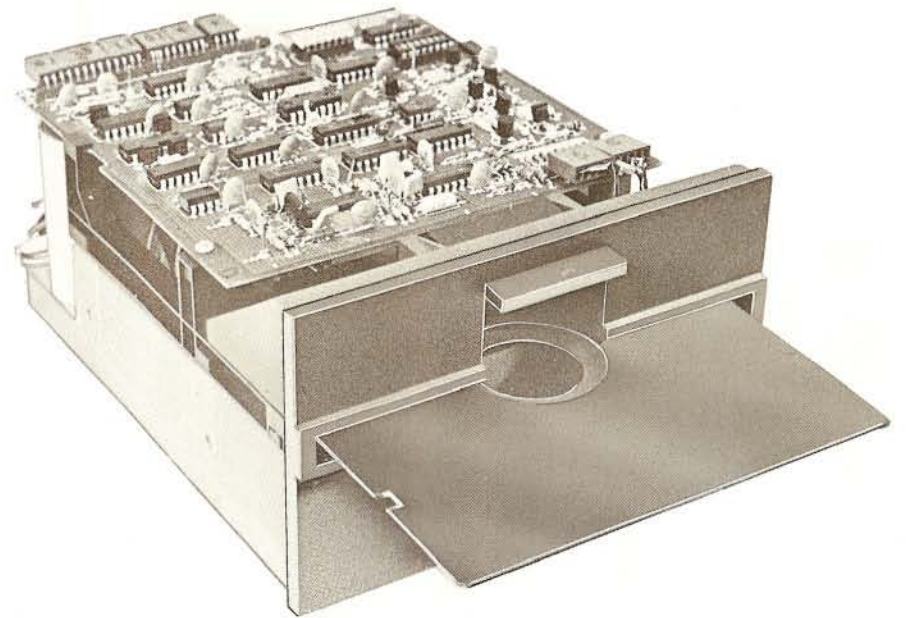

TANDON MAGNETICS CORPORATION
9333 OSO AVENUE
CHATSWORTH, CALIFORNIA 91311
(213) 993-6644

TM 100 DISK DRIVE
OPERATING & SERVICE MANUAL

PROPRIETARY NOTICE

Information contained in this document is copyright by TANDON MAGNETICS CORPORATION and may not be duplicated in full or in part by any person without prior written approval of TANDON MAGNETICS CORPORATION. It is provided as an aid to the user with no guarantee, written or implied, that the document is accurate with regard to any specification.

© copyright 1979 TANDON MAGNETICS CORPORATION

TABLE OF CONTENTS

SECTION I	GENERAL DESCRIPTION AND SPECIFICATIONS	1
	Introduction . . . Purpose of Equipment . . . Physical Description of Equipment . . . Functional Description . . . Diskettes . . . Mechanical and Electrical Specifications . . . Interface Specifications . . . Uncrating the Disk Drive . . . Physical Checkout . . . Interface Connections . . . Chassis Ground . . . Mounting the Disk Drive . . . Diskette Handling and Storage . . . Loading the Diskette . . . Write Protect . . . DC Power Requirements.	
SECTION II	THEORY OF OPERATION	9
	Introduction . . . Organization of the Disk Drive . . . Functional Block Diagram Description . . . Index . . . Write Protect . . . Track 00 Switch . . . Spindle Drive . . . Positioner Control . . . Data Electronics	
SECTION III	OPERATION	14
	Introduction . . . Physical Description of PCBA's . . . Interface Electronics Specifications . . . Circuit Board Test Points . . . Option Select . . . Adjustment	

LIST OF ILLUSTRATIONS

Figure 1	— TM 100 Disk Drive	1
Figure 2	— Recording Medium	3
Figure 3	— Outline TM100 Disk Drive	5
Figure 4	— Diskette Care and Handling	6
Figure 5	— Diskette Access	7
Figure 6	— Write Protect Tab	8
Figure 7	— TM100 Functional Block Diagram	10
Figure 8	— FM Recording	11
Figure 9	— Write Timing Diagram	12
Figure 10	— Read Timing Diagram	13
Figure 11	— Logic P.C.B.A.	14
Figure 12	— Servo P.C.B.A.	15
Figure 13	— Interface Configuration	15
Figure 14	— Catseye Pattern	20
Figure 15	— Index to Data	21

LIST OF TABLES

Table 1	— Mechanical and Electrical Specifications	4
Table 2	— Interface Connector Pin Assignments, J1/P1	16
Table 3	— Power Connector Pin Assignment	16

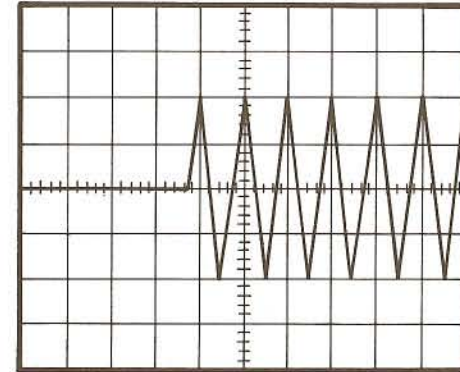

TIME SCALE = 50 usec/DIV.

INDEX TO DATA

Fig. 15

3.6.2 TRACK 00 SWITCH

- (1) Apply the necessary power and control to turn on the drive.
- (2) Insert the CE Alignment Diskette into the drive and close the front latch.
- (3) Position the carriage to the radial alignment track. Confirm the position by observing the cats-eye pattern.
- (4) If adjustment is required, remove the CE Diskette. Loosen the retaining screw on the base of the Track 00 Bracket, retighten slightly to provide some friction on the bracket and rotate the Track 00 Adjustment Screw (located at the rear of the chassis) counter-clockwise as far as it will go without forcing it.
- (5) Position the carriage to Track 01.
- (6) Rotate the Track 00 Adjustment Screw clockwise—very slowly—until the switch “clicks”. Then rotate the screw clockwise (same direction) exactly one-half turn.
- (7) Tighten the retaining screw previously loosened.

3.6.3 WRITE PROTECT SWITCHES

- (1) Insert a non-write protected diskette partially (halfway) into the drive.
- (2) Ensure that the switch is actuated.
- (3) Insert diskette fully against diskette back stop and close the front latch. Ensure that the switch is deactivated.
- (4) Adjust switch by loosening the retaining screw, removing switch assembly and setting switch higher or lower as required.

3.6.4 DRIVE MOTOR SPEED

- (1) Apply necessary power and control to turn on the drive.
- (2) Insert diskette.
- (3) Ensure that Drive Motor Enable line is active.
- (4) Adjust Speed Control potentiometer (on servo PCBA) until timing disk is stationary in fluorescent lighting.

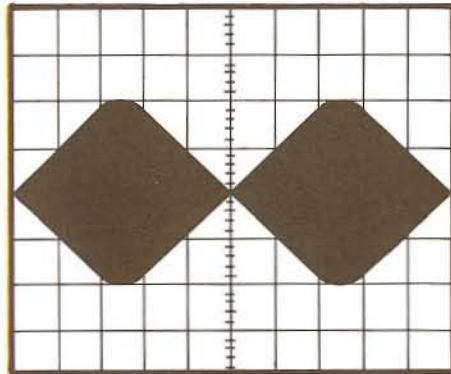

EQUAL AMPLITUDE
(ON TRACK 16)

TIME SCALE = 20 ns/DIV.

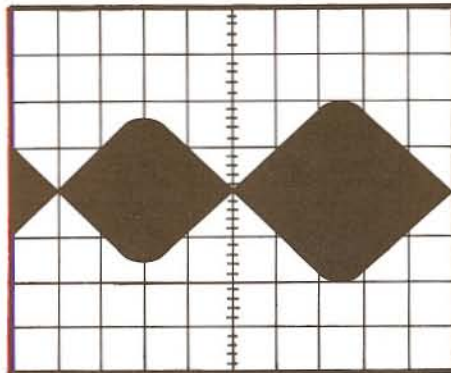

ONE IS 75% OF THE OTHER
(1 MIL OFF TRACK)

TIME SCALE = 20 ns/DIV.

CATSEYE PATTERN

Fig. 14

SECTION I GENERAL DESCRIPTION AND SPECIFICATIONS

1.1 INTRODUCTION

This section provides the physical and functional specifications for the TM100 Disk Drive, manufactured by TANDON MAGNETICS CORPORATION.

1.2 PURPOSE OF THE DRIVE

The TM100 Disk Drive is a "MINI" Disk Memory designed for random access data entry, storage, and retrieval applications. These applications typically are intelligent terminal controllers, micro-computers, word processing systems, data communications systems, error logging, micro-program loading, and point of sale terminals.

The TM100 is capable of recording and reading digital data using FM, MFM, or M²FM techniques.

1.3 PHYSICAL DESCRIPTION OF THE DRIVE

The TM100 Disk Drive is shown in Figure 1. The Drives can be mounted in any vertical or horizontal plane; however, when mounted horizontally, the printed circuit logic board must be uppermost.

The spindle is belt driven by a dc motor with an integral tachometer. The servo control circuit, suitably sized pulleys, and the tachometer control the speed of the spindle. The read/write double-sided head assembly is positioned by means of a stepper motor, split band, and a suitably sized pulley.

The read/write/erase head assembly is a glass-bonded ferrite/ceramic structure which has a life in excess of 20,000 hours.

Operator access for diskette loading is provided via a slot located at the front of the unit.

The electronic components of the Drive are mounted on two PCBA's, one of which (logic) is located above the chassis, the other (servo) is mounted at the rear of the unit. Power and interface signals are routed through connectors which plug directly into the logic PCBA.

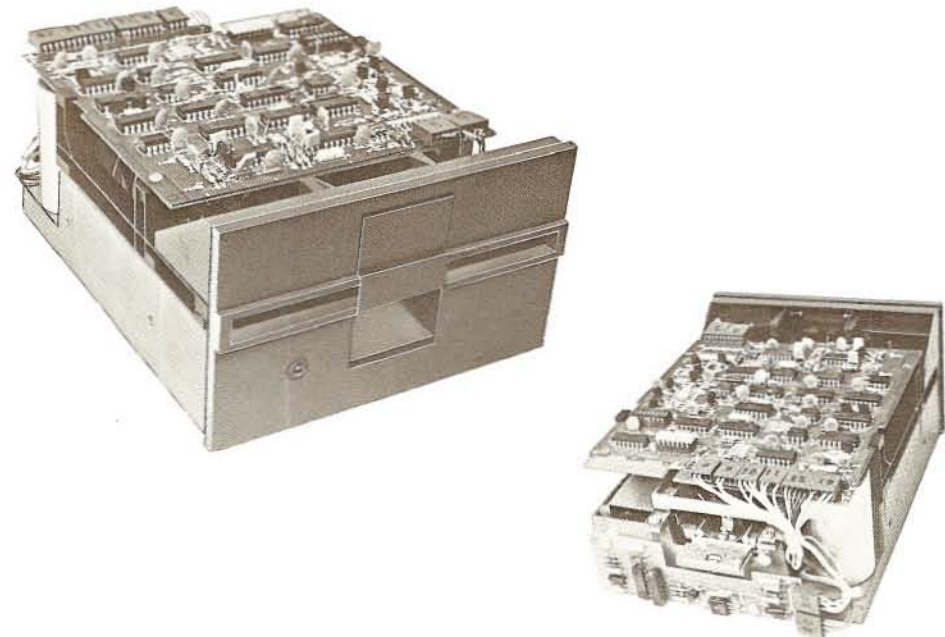

TM 100 DISK DRIVE

Fig. 1

1.4 FUNCTIONAL DESCRIPTION OF THE DRIVE

The Disk Drive is fully self-contained and requires no operator intervention during normal operation. The Drive consists of a spindle drive system, a head positioning system, and read/write/erase system.

When the front latch is opened, access is provided for the insertion of a diskette. The diskette is positioned in place by plastic guides, and the front latch. In/out location is ensured when the diskette is inserted until a back stop is encountered.

Closing the front latch activates the cone/clamp system resulting in centering of the diskette and clamping of the diskette to the drive hub. The drive hub is driven at a constant speed of 300 rpm by a servo controlled dc motor. In operation, the magnetic head is loaded into contact with the recording medium whenever the front latch is closed.

The magnetic head is positioned over the desired track by means of a 4-phase stepper motor/band assembly and its associated electronics. This positioner employs a one-step rotation to cause a 1-track linear movement. When a write-protected diskette is inserted into the Drive, the write-protect sensor disables the write electronics of the Drive and an appropriate signal is applied to the interface.

When performing a write operation, a 0,33 mm (0.013-inch) (nominal) data track is recorded. This track is then tunnel erased to 0,30 mm (0.012 inch) (nominal).

Data recovery electronics include a low-level read amplifier, differentiator, zero-crossing detector, and digitizing circuits.

No data decoding facilities are provided in the basic Drive.

The Drive is also supplied with the following sensor systems:

- (1) A Track 00 switch which senses when the Head/Carriage assembly is positioned at Track 00.
- (2) The index sensor, which consists of an LED light source and phototransistor, is positioned such that when an index hole is detected, a digital signal is guaranteed. The index sensor used is a high resolution device which can distinguish holes placed close together, i.e., Index-Sector holes in a hard sector diskette.
- (3) The write-protect sensor disable the Disk Drive electronics whenever a write-protect tab is applied to the diskette (see section 1.15 and figure 6).

1.5 DISKETTES

The TM100 uses a standard 133.4 mm (5.25 inch) diskette. These diskettes are available with a single index hole or multiple holes.

Diskettes with a single hole are used when sector information is prerecorded on the diskette. Multiple hole diskettes provide sector information by means of the index sensor and electronics.

Figure 2 is a simplified drawing of the diskette used with the Disk Drive. It can be seen that this recording medium is a flexible magnetic disk enclosed in a protective jacket. The protected disk, free to rotate within the jacket, is continuously cleaned by the soft fabric lining of the jacket during normal operation.

1.6 MECHANICAL AND ELECTRICAL SPECIFICATIONS

The mechanical and electrical specifications for the Disk Drive are given in Table 1.

1.7 INTERFACE SPECIFICATIONS

Levels: True = +0.4v (maximum)
False = +2.4v (minimum)

The interface circuits are designed so that a disconnected wire results in a false signal.

1.8 UNCRATING THE DISK DRIVE

The Disk Drive is shipped in a protective container which, when bulk packaged, minimizes the possibility of damage during shipment. The following procedure describes the recommended method for uncrating the Disk Drive.

- (1) Place the container on a flat work surface.
- (2) Remove the outer cardboard sleeve from around the inner container.
- (3) Remove the upper half of the inner container.
- (4) Remove the Disk Drive from the lower half of the inner container.
- (5) Check the contents of the shipping container against the packing slip. Investigate the contents for possible damage; notify the carrier immediately if any damage is noted.

In a multiple drive system (program shunt position "MX" open) the three input lines (Drive Select 1, Drive Select 2 and Drive Select 3) are provided so that the using system may select which drive on the interface is to be used. In addition, Drive Select 4 is provided as an option. In this mode of operation, only the Drive with its Drive Select line active will respond to the input lines and gate the output lines.

The program shunt, IC location 1E, positions "DS1", "DS2" and "DS3", are to be used to select which Drive Select line will activate the I/O lines for a unique drive. As an example, if the user wants the first drive on the interface to be addressed as drive #1, he must cut program shunt positions "DS2" and "DS3", and leave "DS1" intact.

The program shunt is AMP part number 435704-7. The shunt positions can be cut using AMP's tool part number 435705. The shunt is installed in a dip socket. At the users option, it can be removed/replaced by a dip switch. The user may also choose to have the program shunts preprogrammed and/or color coded by AMP. For this service, contact your local AMP representative.

3.6 ADJUSTMENT

3.6.1 CE ALIGNMENT

The CE alignment procedure locates the magnetic read/write head at the proper radial distance from the hub centerline, thus assuring accurate track location. This adjustment is necessary only after service, or for suspected diskette interchange problems.

3.6.1.1 DISK DRIVE PREPARATION

- (1) Apply the necessary power and control to turn on the Disk Drive.
- (2) Insert a CE Alignment Diskette (Dysan Part No. 224-2A or equivalent) into the drive and close the front latch.
- (3) Attach oscilloscope signal probes to test points TP1 and TP2. Place ground clip of signal probes to TP10. Adjust the oscilloscope to read differentially (A + B with B inverted). Sync the oscilloscope on the leading edge of the Index pulse at TP7 with sync probe ground clip at TP6.

3.6.1.2 RADIAL TRACK ALIGNMENT

- (1) Select HD "0".
- (2) Loosen (do not remove) the two module retaining screws on the bottom of the chassis, and the one at the top rear of module.
- (3) Follow instructions accompanying the CE Diskette, Typically Track 16.
- (4) Manually rotate the cam at the rear of the module until the cats-eye pattern shown in Figure 14 is observed. Carefully rotate the cam until the cats-eye pattern has equal amplitudes.
- (5) Secure the module by tightening the (3) retaining screws, previously loosened.
- (6) After securing the module screw, verify Step (4). Repeat as required.
- (7) Check HD1 ensures lobes are within 75% (or 70% with uncertified alignment media) of each other.

3.6.1.3 INDEX SENSOR ALIGNMENT

- (1) Position the Index sensor to center of travel; lightly tighten retaining screw.
- (2) Perform CE alignment as required to locate the cats-eye pattern (refer to Paragraph 3.7.1.2).
- (3) Position the carriage to Track 01.
- (4) Set oscilloscope horizontal time base to 50 usec per division.
- (5) Referring to Figure 15, adjust photo transistor mounting block until the first transistion of the 2 msec burst recorded at Track 01 occurs 200 ±100 usec after the leading edge of the Index pulse. Adjustment may be made with the use of a flat-bladed screwdriver placed between the photo transistor mounting block and chassis as required.
- (6) Secure retaining screw on the photo transistor mounting block and verify burst location; readjust as necessary.

3.3.2.4 READ DATA (NREADDATA)

This interface line transmits the readback data to the controller when the Drive is selected. It provides a pulse for each flux transition recorded on the medium. The READ DATA output line goes true (low) for a duration of 1 usec for each flux change recorded.

The leading edge of the READ DATA output pulse represents the true positions for the flux transitions on the diskette surface.

3.4 CIRCUIT BOARD TEST POINTS

The following test point description assumes that the logic and servo PCBA's are installed in a TM100 Disk Drive and that the Drive is in an operational mode with a diskette installed.

3.4.1 LOGIC GROUND (TP6)

Digital Logic ground is referenced at TP6.

3.4.2 DIFFERENTIATED READ SIGNAL (TP3, TP4)

These test points are provided to observe the differential output of the second stage amplifier and differentiated read signal.

3.4.3 READ DATA SINGLE SHOT (TP5)

The output of the single shot used in the read section is nominally 1.0 usec for each flux transition detected.

3.4.4 INDEX PULSE (TP7)

With a standard soft sectored diskette installed, the signal is high going pulse nominally 3.5 msec in duration every 200 msec.

3.4.5 AMPLIFIED READ SIGNAL (TP1, TP2)

These test points are provided to observe the differential output of the first stage of read signal amplification.

3.4.6 MOTOR ON (TP13)

This signal is low true for the "motor on" condition.

3.4.7 TRACK 00 (TP8)

This signal is low true when the carriage is positioned at track 00 and the step motor phase is correct.

3.4.8 ANALOG GROUND (TP10)

Analog ground reference point is provided for measuring read/write waveforms.

3.4.9 (TP11) NOT FOR USE

3.4.10 STEP PULSE (TP12)

When stepping in or out the signal is a high going pulse for each step of the carriage.

3.4.11 WRITE PROTECT SWITCH (TP9)

When a write protected diskette is installed in the Drive the signal is high.

3.5 OPTION SELECT

3.5.1 INPUT LINE TERMINATIONS

The TM100 has been provided with the capability of terminating the input lines listed below:

- * Motor On
- * Direction Select
- * Step
- * Write Data
- * Side Select

These lines are terminated through a 150 ohm resistor pack installed in a dip socket located at IC location 2F.

In a single drive system this resistor pack should be kept in place to provide the proper terminations.

In a multiple drive system (Program Shunt position "MX" open) only the last drive on the interface is to be terminated. All other drives on the interface must have the resistor pack removed.

3.5.2 DRIVE SELECT 1-4

The TM100 as shipped from the factory is configured to operate in a single drive system. It can be easily modified by the user to operate with other drives in a multiplexed multiple drive system. The user can activate the multiplex option by cutting the "MX" position of the programmable shunt located in IC location IF. This will allow the multiplexing of the I/O lines.

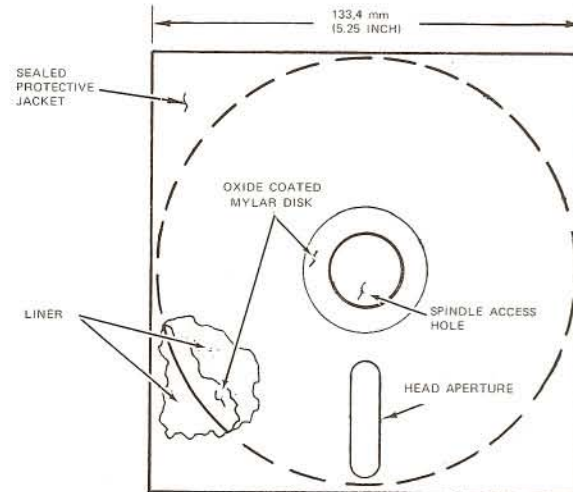
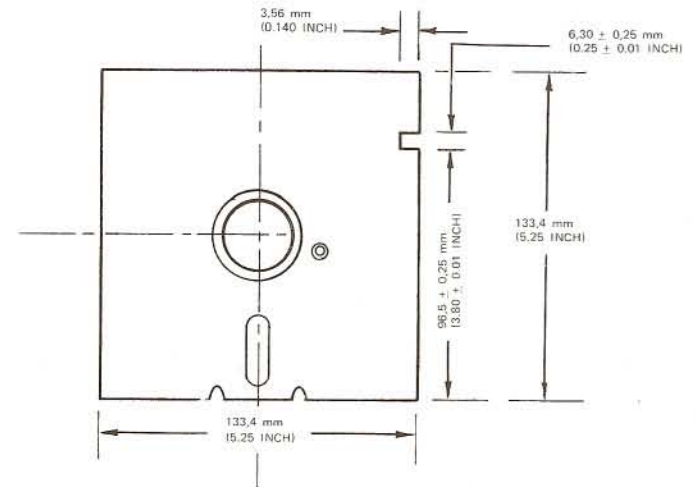

RECORDING MEDIUM

Fig. 2

1.9 PHYSICAL CHECKOUT

Before applying power to the unit, the following inspection should be performed:

- (1) Front latch. Check that the front latch opens and closes. Note that when the door is opened, the head arm raises.
- (2) Ensure that the front panel is secure.
- (3) Manually rotate the drive hub. The hub should rotate freely.
- (4) Check that PCBA's are secure. Check that the connectors are firmly seated.
- (5) Check for debris or foreign material between the heads and remove same.

TABLE 1

MECHANICAL AND ELECTRICAL SPECIFICATIONS

Media	Industry-compatible 5¼-inch diskette
Tracks per inch	48
Number of Tracks	80 (40 per side)
Dimensions	
Height	85,85 mm (3.38 inches)
Width	149,10 mm (5.87 inches)
Depth	203,2 mm (8.0 inches)
Weight	2.04 Kg (4.5 lbs.)
Temperature	
(Exclusive of Media)	
Operating	10°C to 44°C (50°F to 112°F)
Non-operating	-40°C to 71°C (-40°F to 160°F)
Relative Humidity	
(Exclusive of Media)	
Operating	20% to 80% (Non-condensing)
Non-operating	5% to 95% (Non-condensing)
Seek Time	5 msec track to track
Head Setting Time	15 msec (last track addressed)
Error Rate	1 per 10 ⁹ (recoverable) 1 per 10 ¹² (non-recoverable) 1 per 10 ⁶ (seeks)
Head Life	20,000 hours (normal use)
Media Life	3.6 x 10 ⁶ passes per track
Disk Speed	300 rpm ± 1.5% (long term)
Instantaneous Speed Variation	± 3.0%
Start/Stop Time	250/150 msec (maximum)
Transfer Rate	FM 125K bits/sec MFM 250K bits/sec
Bits/Disk (unformatted)	2.00 million (FM)
Recording Modes (typical)	FM, MFM, MMFM
Power	+12 dc ± 0.6v 900 ma AVE. +5v dc ± 0.25v, 600 ma AVE.

3.3.1.2 DRIVE MOTOR ENABLE (NMOTORON)

When this signal line logic level goes true (low), the drive motor accelerates to its nominal speed of 300 rpm and stabilizes in less than 250 msec. When the logic level goes false (high), the Disk Drive decelerates to a stop.

3.3.1.3 DIRECTION and STEP Lines (2 Lines) (DIR) (NSTEP)

When the Disk Drive is selected, a true (low) pulse with a time duration greater than 200 nsec on the STEP line initiates the access motion. The direction of motion is determined by the logic state of the DIRECTION line when a STEP pulse is issued. The motion is towards the center of the disk if the DIRECTION line is in the true (low) state when a STEP pulse is issued. The direction of motion is away from the center of the disk if the DIRECTION line is in the false (high) state when a STEP pulse is issued. To ensure proper positioning the DIRECTION line should be stable 0.1 usec (minimum) before the trailing edge of the corresponding STEP pulse and remain stable until 0.1 usec after the trailing edge of the STEP pulse. The access motion is initiated on the trailing edge of the STEP pulse.

3.3.1.4 WRITE DATA (NWRITEDATA)

When the Disk Drive is selected, this interface line provides the bit-serial WRITE DATA pulses that control the switching of the write current in the heads. The write electronics must be conditioned for writing by the WRITE ENABLE line (see Paragraph 3.3.1.5).

For each high-to-low transition on the WRITE DATA line, a flux change is produced at the head write gap. This causes a flux change to be stored on the disk.

When the double-frequency type encoding technique is used (in which data and clock form the combined Write Data signal), it is recommended that the repetition of the high-to-low transitions, when writing all zeros, be equal to the nominal data rate ±0.1 percent. The repetition rate of the high-to-low transitions, when writing all ones, should be equal to twice the nominal data rate, ±0.1 percent.

3.3.1.5 WRITE ENABLE (NWRITEGATE)

When this signal is true (low), the write electronics are prepared for writing data (read electronics disabled). This signal turns on write current in the read/write head. Data is written under control of the WRITE DATA input line. It is generally recommended that changes of state on the WRITE ENABLE line occur before the first WRITE DATA pulse. However, the separation between the leading edge of WRITE ENABLE and the first significant WRITE DATA pulse should not be less than 4 usec and not greater than 8 usec. The same restrictions exist for the relationship between the least significant WRITE DATA pulse and the termination of the WRITE ENABLE signal. When the WRITE ENABLE line is false (high), all write electronics are disabled.

When a write-protected diskette is installed in a TM100 Disk Drive, the write electronics are disabled irrespective of the state of the WRITE ENABLE LINE.

3.3.1.6 SIDE SELECT (NSIDESELECT)

When this signal is true (low) side 1 of the disk is selected for read/write operations. When the signal is false (high) side 0 of the disk is selected. This signal must be stable during an entire read or write operation. This signal is best implemented in synchronization with the device select line signal. (See Paragraph 3.3.1.1.)

3.3.2 OUTPUT STATUS (See Table 2)

3.3.2.1 INDEX (NINDEX/SECTOR)

The INDEX signal is provided once each revolution (200 msec, nominal) to indicate to the controller the beginning of a track. The INDEX line remains in the true (low) state for the duration of the INDEX pulse. The duration of an INDEX pulse is nominally 4.0 msec.

The leading edge of an INDEX pulse must always be used to ensure diskette interchangeability between Disk Drives.

3.3.2.2 TRACK 00 (NTRK00)

When the Disk Drive is selected, the TRACK 00 interface signal indicates to the controller that the read/write head is positioned at Track 00. The TRACK 00 signal remains true (low) until the head is moved away from Track 00.

3.3.2.3 WRITE PROTECT (NWRITEPROTECT)

When the Disk Drive is selected, this signal line logic level goes true (low) when the diskette is write protected. The write electronics are internally disabled when the diskette is write protected.

NOTE

It is recommended that the write data line be inactive whenever Write Enable is false (i.e., read state).

When the level on this line is false (high), the write electronics are enabled and the write operation can be performed. It is recommended that the controller not issue a write command when the WRITE PROTECT signal is true (low).

TABLE 2
INTERFACE CONNECTOR PIN ASSIGNMENTS, J1/P1

Controller-to-Disk Drive		
Ground	Signal	Description (Mnemonic)
1	2	Connector clamp
3	4	(Spare)
5	6	SELECT 3 (NDS3)
9	10	SELECT 0 (NDS0)
11	12	SELECT 1 (NDS1)
13	14	SELECT 2 (NDS2)
15	16	DRIVE-MOTOR ENABLE (NMOTORON)
17	18	DIRECTION
19	20	STEP (NSTEP)
21	22	WRITE DATA (NWRITEDATA)
23	24	WRITE GATE (NWRITEGATE)
31	32	SIDE SELECT (NSIDE SELECT)

Disk Drive-to- Controller		
Ground	Signal	Description (Mnemonic)
7	8	INDEX (NINDEX/SECTOR)
25	26	TRACK 00 (NTRK00)
27	28	WRITE PROTECT (NWRITEPROTECT)
29	30	READ DATA (NREADDATA)
33	34	Connector Clamp

TABLE 3
POWER CONNECTOR PIN ASSIGNMENT

Pin	Supply Voltage
1	+12v dc
2	Return (+12v dc)
3	Return (+5v dc)
4	+5v dc

1.10 INTERFACE CONNECTIONS

Signal connections for the TM100 are made via a user-supplied 34-pin flat ribbon connector (3M Part No. 3463-0001 or equivalent). This connector mates directly with the PCBA connector at the rear of the Drive. The dc power connector is a four-pin connector (Amp Mate-N-Lok, Part No. 1-480424-0) which mates with the connector on the logic PCBA at the top rear of the Drive. The interface description of the connectors, and the location of each, is contained in Section III.

The signal connector harness should be of the flat ribbon or twisted pair type with the following characteristics:

- (1) Maximum length of 10 feet.
- (2) 22 - 24 gauge conductor compatible with the connector to be used.

Power connections should be made with 18 AWG cable (minimum). In addition, the PCBA mounted dc power connector is keyed.

1.11 CHASSIS GROUND

To ensure proper operation of the Drive, the chassis should be connected to earth ground. The 3/16" male QC lug, located at the rear of the chassis, is provided to facilitate this connection.

1.12 MOUNTING THE DISK DRIVE

The Drive has been designed such that it can be mounted in any plane, i.e., upright, horizontal, or vertical. The only mounting restriction is that when mounted horizontally, the logic PCBA side of chassis must be the uppermost side. Tapped holes are provided in various locations for the attachment of user supplied hardware. Figure 3 shows the location of the recommended mounting holes.

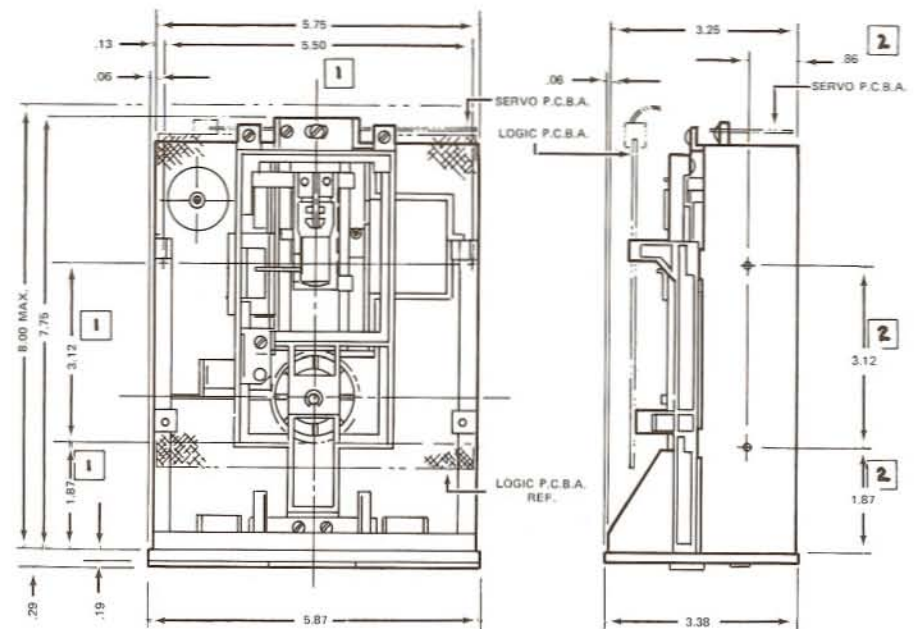

- 1** FOUR (4) MOUNTING HOLES ON UNIT FAR SIDE (BOTTOM). No. 6-32 UNC-28 x .31 DP.
- 2** FOUR (4) MOUNTING HOLES, TWO (2) ON EACH SIDE. No. 6-32 UNC-28 x .31 DP.

OUTLINE - TM100 DISK DRIVE

Fig. 3

1.12.1 HARDWARE

The Disk Drive is manufactured with certain critical internal alignments that must be maintained. Therefore, it is important that the mounting hardware does not introduce significant stress on the Drive.

Any mounting scheme in which the Drive is part of the structural integrity of the enclosure is not permitted.

Mounting schemes should allow for adjustable brackets or incorporate resilient members to accommodate tolerances.

Mounting schemes involving more than three mounting points should be avoided.

1.12.2 DUST COVER

Since the Disk Drive is not provided with a dust cover, the design of an enclosure should incorporate a means to prevent contamination from loose items, e.g., dust, lint, paper chad, etc.

1.12.3 COOLING

Heat dissipation from a single Disk Drive is normally 15 watts (51 Btu/Hr) under high line conditions. When the Drive is mounted so that the components have access to the free flow of air, normal convection cooling allows operation over the specified temperature range.

When the Drive is mounted in a confined environment, air flow must be provided to maintain specified air temperatures in the vicinity of the motors, PCBA's, and diskette.

1.12.4 DRIVE SEPARATION

In addition to the cooling requirements specified in Paragraph 1.12.3, a minimum separation of 25,4 mm (1 inch) between Drives is recommended. This is required to avoid electrical interference between the motors of one Drive and the magnetic head of another Drive. Closer mounting is allowable if a gounded sheet of steel at least 1,52 mm (0.060-inch) thick is placed between units. However, use of this steel sheet may increase the cooling requirements.

1.13 DISKETTE HANDLING AND STORAGE

It is important that the diskette be handled and stored properly so that the integrity of the recorded data is maintained. A damaged or contaminated diskette can impair or prevent recovery of data and can result in damage to the read/write heads.

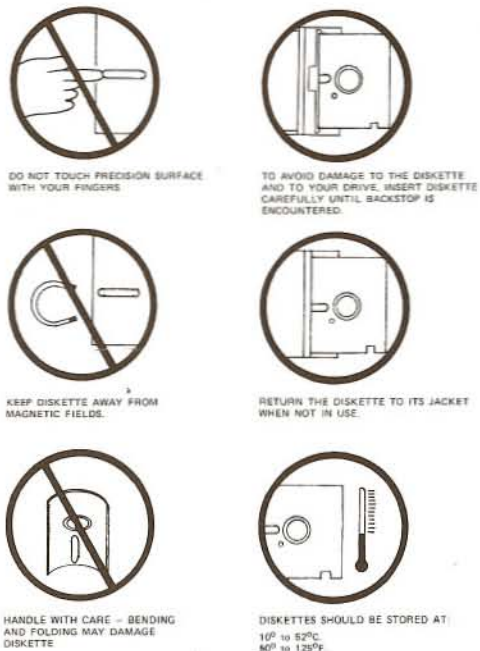

DISKETTE CARE AND HANDLING

Fig. 4

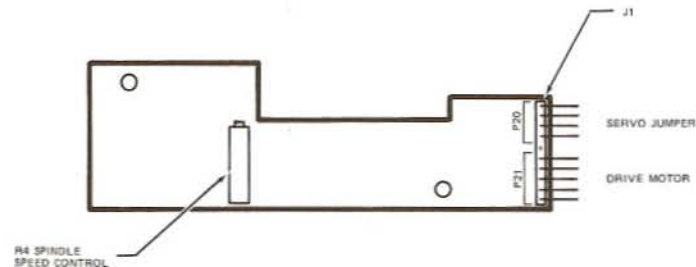

SERVO P.C.B.A.

Fig. 12

3.3 INTERFACE ELECTRONICS SPECIFICATIONS

All interface signals are TTL compatible. Logic true (low) is +0.4v (maximum), logic false (high) is +2.4v (minimum). Figure 13 illustrates the interface configuration. Maximum interface cable length is 10 feet.

It is recommended that the interface cable be flat ribbon cable, with a characteristic impedance of 100 ohms (or equivalent twisted pairs).

Interface connector pin assignments and power connector pin assignments are given in Table 2 and Table 3.

3.3.1 INPUT CONTROL LINES (See Table 2)

3.3.1.1 SELECT LINES (NDS1-NDS4)

The SELECT lines provide a means of selecting and deselecting a Disk Drive. These four lines (NDS0-NDS3 standard) select one of the four Disk Drives attached to the controller. When the signal logic level is true (low), the Disk Drive electronics are activated and the Drive is conditioned to respond to step or read/write commands. When the logic level is false (high), the input control lines and output status lines are disabled.

A SELECT line must remain stable in the true (low) state until the execution of a step or read/write command is completed.

The Disk Drive address is determined by a Select Shunt on the PCBA. SELECT lines 0-3 provide a means of daisy-chaining a maximum of four Disk Drives to a controller. Only one line can be true (low) at a time. An undefined operation might result if two or more units are assigned the same address or if two or more SELECT lines are in the true (low) state simultaneously.

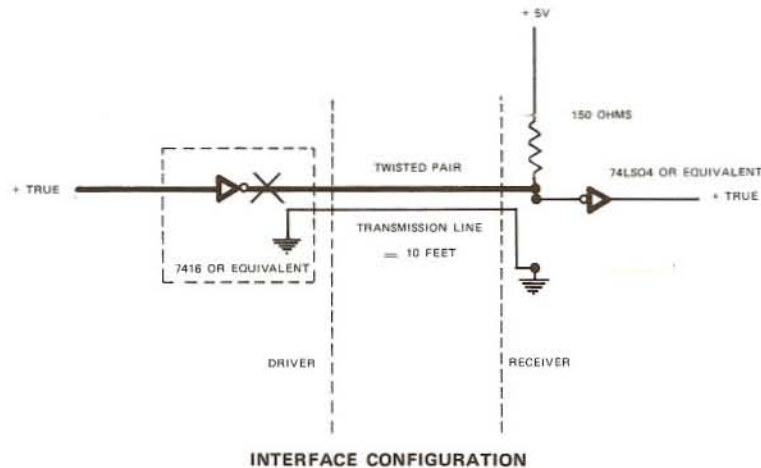

INTERFACE CONFIGURATION

Fig. 13

SECTION III
OPERATION

3.1 INTRODUCTION

This section contains the interface description and the mechanical/electrical adjustments necessary for the TM100 Disk Drive. Also presented are schematic diagrams of the PCBA's installed in the Disk Drive.

3.2 PHYSICAL DESCRIPTION OF THE PCBA'S

The logic PCBA is approximately 146 mm (5.75 inches) long by 146 mm (5.75 inches) wide, and the servo PCBA is approximately 127 mm (5.0 inches) long by 38 mm (1.5 inches) wide. Figures 11 and 12 illustrate the placement of test points and connectors.

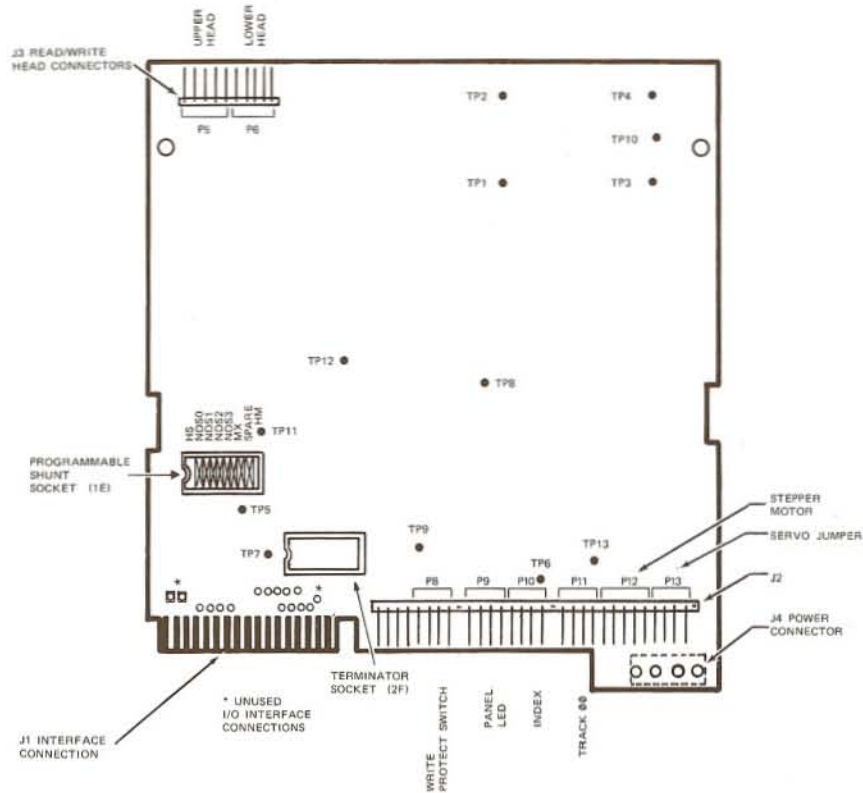

LOGIC P.C.B.A.

Fig. 11

Figure 2 illustrates the physical configuration of the diskette. The diskette is an oxide coated, flexible mylar disk, 130.2 mm (5.125 inches) in diameter, and is enclosed in an 133.4 mm x 133.4 mm (5.25 x 5.25-inch) protective jacket. Read/write/erase head access is made through an aperture in the jacket. Openings for the drive hub and diskette index hole are also provided.

Figure 4 provides some helpful hints on the care and handling of the Disk Drive and diskettes. Additionally, to assure trouble-free operation and enhance the service life of the diskette, the following procedures for handling should be observed:

- Return the diskette to the protective jacket when not in use.
- Avoid exposing the diskette to any magnetizing force in excess of 50 oersted.

NOTE

The 50 oersted level of magnetizing force is reached at a distance of approximately 76 mm (3 inches) from a typical source, e.g., motors, generators, transformers.

- Do not store the diskette in direct sunlight as warping could result.
- Do not use a lead pencil or ballpoint pen to write on the label. Use a felt tip pen and mark lightly on the label.

1.14 LOADING THE DISKETTE

Diskette loading is accomplished by inserting the properly oriented diskette into the front slot provided. Access to the diskette loading slot is obtained by opening the front latch. See Figure 5.

The diskette should be carefully inserted until the diskette jacket is solidly against the backstop.

CAUTION

DAMAGE TO THE CENTER HOLE IN THE DISKETTE MAY RESULT IF THE DOOR IS CLOSED WHEN THE DISKETTE IS NOT PROPERLY INSERTED. THIS WILL PREVENT RELIABLE RECOVERY OF THE RECORDED DATA.

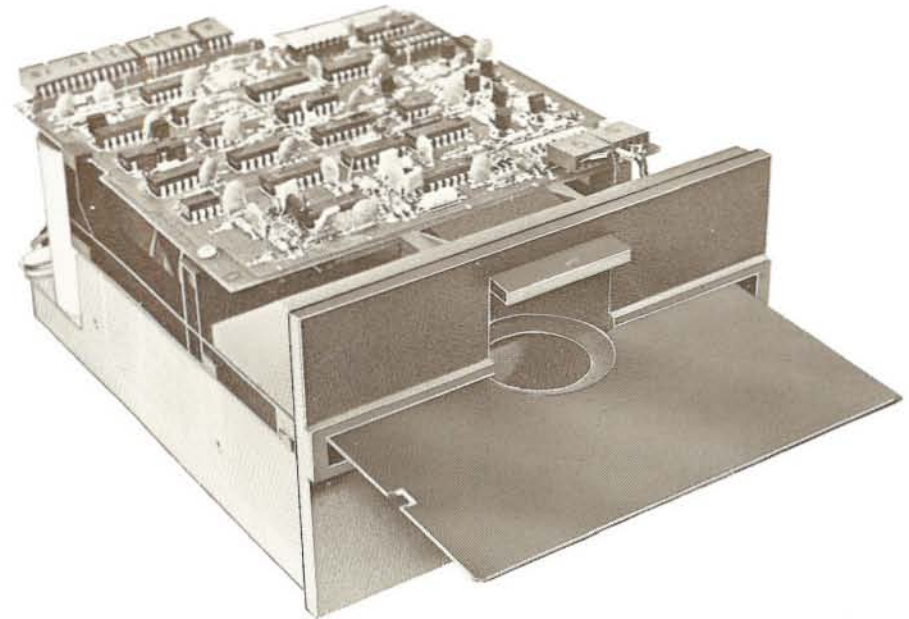

DISKETTE ACCESS

Fig. 5

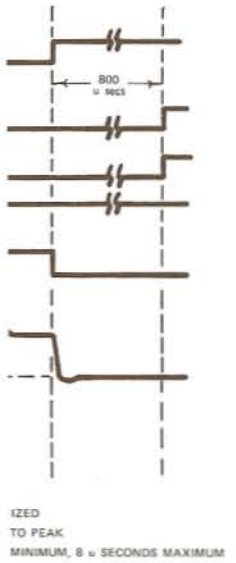

IZED
TO PEAK
MINIMUM, 8 μ SECONDS MAXIMUM

cross the magnetic head heads.

recording operation, this requirements established in IASE signal to allow the Read mode.

by a read amplifier and Filter is passed to the the peaks of the read

onding to each peak of 1 via the READ DATA

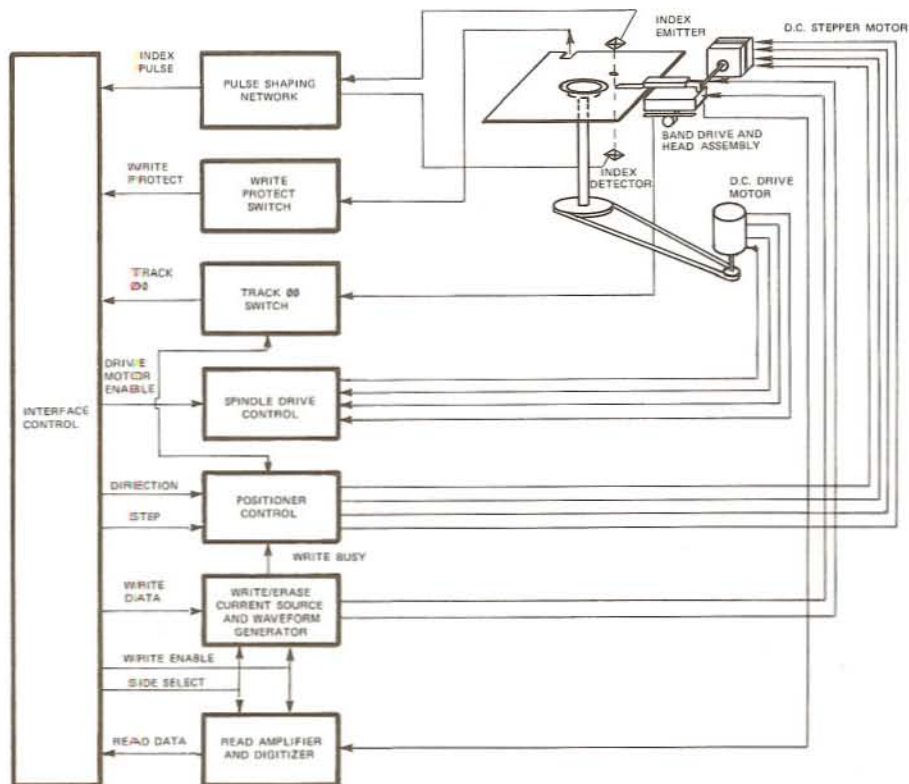

TM 100 FUNCTIONAL BLOCK DIAGRAM

Fig. 7

2.9 POSITIONER CONTROL

The Head Positioning system utilizes a four-phase stepper motor drive which changes one phase for each track advancement of the Read/Write carriage. In addition to the logic necessary for motion control, a gate is provided as an element for inhibiting positioner motion during a write operation.

2.10 DATA ELECTRONICS

Information can be recorded on the diskette using a double-frequency code. Figure 8 illustrates the magnetization profiles in each bit cell for the number sequence shown.

The erase gaps provide an erased guard band on either side of the recorded track. This accommodates the tolerances in track positioning.

All signals required to control the data electronics are provided by the user system and are shown in the block diagram, Figure 7. These control signals are:

- * SELECT
- * WRITE ENABLE
- * WRITE DATA
- * SIDE SELECT

The READ DATA composite signal is sent to the user system via the interface.

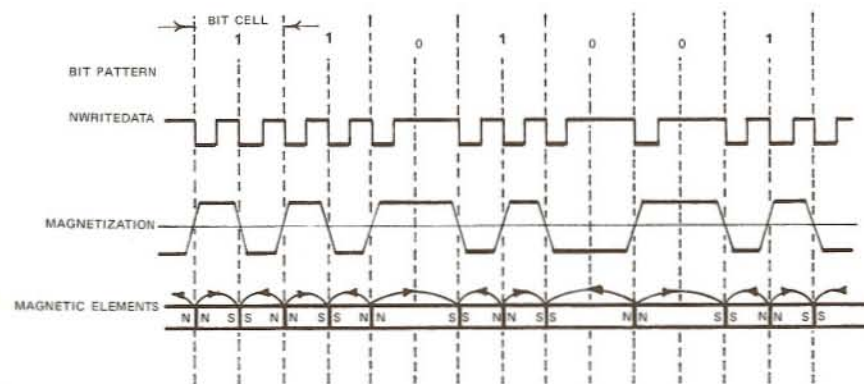

F M RECORDING

Fig. 8

2.10.1 DATA RECORDING

Referring to Figure 7, it can be seen that the Write Electronics consist of a Write/Erase Current Source and Write Waveform Generator, Erase Current Source, Trim Erase Control Logic, and Head Select Logic.

The read/write winding on the magnetic head is center-tapped. During a write operation, current from the Write Current Source flow in alternate halves of the winding under control of the Write Waveform Generator.

Before recording can begin, certain conditions must be satisfied. The conditions required for recording (i.e., unit ready) must be established by the user system as follows:

- (1) Drive speed stabilization. This condition will exist 250 msec after starting the drive motor.
- (2) Subsequent to any step operation, the positioner must be allowed to settle. This requires 20 msec total after the last step pulse is initiated, i.e., 5 msec for the step motion and 15 msec for settling.

NOTE

All of the foregoing operations can be overlapped, if required.

Figure 9 shows the relevant timing diagram for a write operation. At $t = 0$ when the unit is ready, the WRITE ENABLE interface line goes true, this enables the Write Current Source.

Since the trim erase gaps are behind the read/write gap, the TRIM ERASE control goes true 390 usec after the WRITE ENABLE interface line. It should be noted that this value is optimized between the requirements at Track 00 and Track 34 so that the effect of the trim erase gaps on previous information is minimized.

Figure 9 shows the information on the WRITE DATA interface line, and the output of the Write Waveform Generator which toggles on the leading edge of every WRITE DATA pulse.

Note that a minimum of 4 usec and a maximum of 8 usec between WRITE ENABLE going true and the first WRITE DATA pulse is only required if faithful reproduction of the first WRITE DATA transition is significant.

At the end of recording, at least one additional pulse on the WRITE DATA line must be inserted after the last significant WRITE DATA pulse to avoid excessive peak shift effects.

The TRIM ERASE signal must remain true for 800 usec after the termination of WRITE ENABLE to ensure that all recorded data are trim erased. This value is again optimized between the requirements at Tracks 00 and 34.

The duration of a write operation is from the true-going edge of WRITE ENABLE to the false-going edge of TRIM ERASE. This is indicated by the internal WRITE BUSY waveform shown.